

STAKED HAYBALE DETAIL
N.T.S.

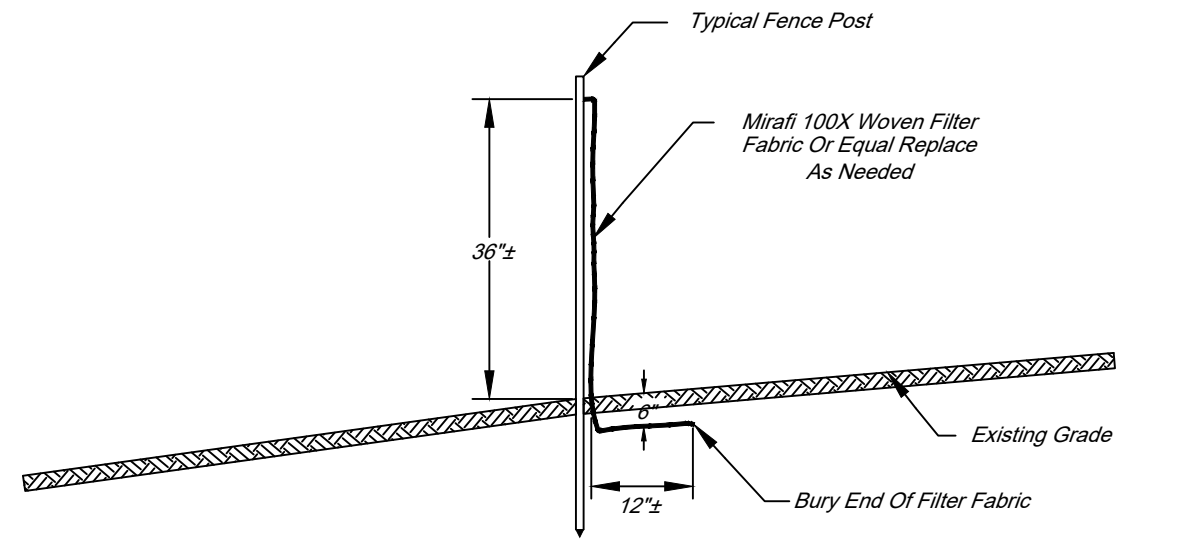

SEDIMENT FILTER FENCE
N.T.S.

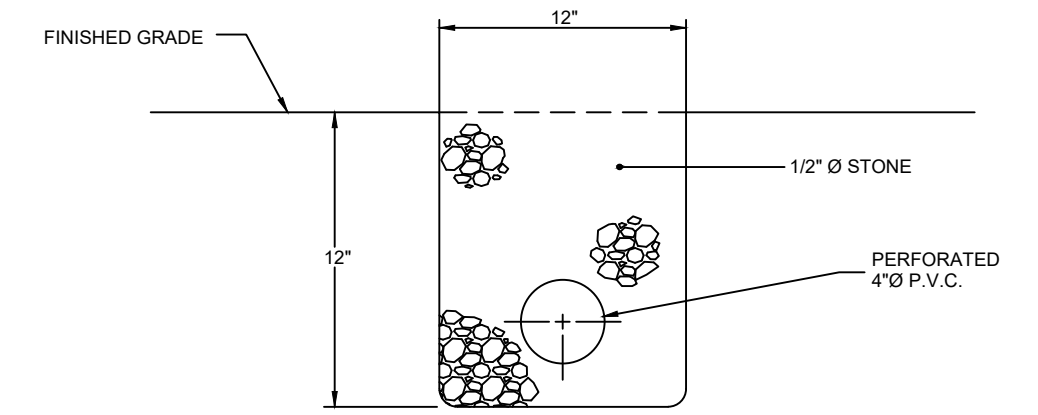

CURTAIN DRAIN CROSS SECTION
N.T.S.



COPYRIGHT © 2020 BY BASCOM & BENJAMIN, LLC
ALL RIGHTS RESERVED. THIS DOCUMENT OR ANY PART THEREOF MUST NOT BE REPRODUCED OR UTILIZED IN ANY FORM WITHOUT WRITTEN PERMISSION OF BASCOM & BENJAMIN, LLC.

LEGEND

EXISTING	PROPOSED
-2.10-	CONTOURS
239 x 57	SPOT ELEVATIONS
▲	CURTAIN DRAIN
△	SURVEY CONTROL POINT
■	SILT FENCE
□	CATCH BASIN
○	UTILITY POLE
---	LIMITS OF CLEARING
	LOC

MAP REFERENCE:
1. PERIMETER SURVEY - PROPERTIES OF E. EILEEN ROSSITER, SUSAN L. CURTIN & GEORGE E. CURTIN, III, 610 & 644 COUNTY ROAD, GUILFORD, CONN. SCALE: 1"=40', DATE: JUNE 4, 2012, BY: ANDERSON ENGINEERING & SURVEYING ASSOCIATES.
2. DATA ACCUMULATION PLAN DIVISION OF PROPERTY OF E. EILEEN ROSSITER, 610 COUNTY ROAD, GUILFORD, CONN. SCALE: 1"=40', DATE: JULY 12, 2012, REVISED 8-6-12, BY: ANDERSON ENGINEERING & ASSOCIATES.

This Survey and Map has been prepared in accordance with SECTIONS 20-300b-1 through 20-300b-20 of the REGULATIONS OF CONNECTICUT STATE AGENCIES "Minimum Standards for Surveys and Maps in the State of Connecticut" as endorsed by the Connecticut Association of Land Surveyors, Inc.

It is a TOPOGRAPHIC SURVEY based on the DEPENDENT RESURVEY METHOD conforming to Vertical Accuracy Class 1-2 and Horizontal Accuracy Class A-2, and is intended to be used for the design of a Site Development Plan for this property.

This map is substantially correct to the best of my knowledge and belief.

Robert A. Bascom, L.S. Conn. License #14,199

REVISIONS			
NO.	DESCRIPTION	BY	DATE
1	GARAGE LOCATION	P.B.	12-16-20
2	GARAGE LOCATION	P.B.	1-5-21

#644 COUNTY ROAD
GUILFORD, CT.

PROPERTY OF:
JEANETTE GOODWIN & CHRISTINE A VOGT

DESIGNED BY: P.M.B.	SITE DEVELOPMENT PLAN	PROJECT NO. 999-01
DRAWN BY: S.M.S.		SHEET NO. 1 OF 1
CHECKED BY: P.M.B.		SCALE: 1"=20'
APPROVED BY:		DATE: 12-1-20

BASCOM & BENJAMIN, LLC
SURVEYING and ENGINEERING CONSULTANTS
360 MAIN STREET DURHAM, CONN
TEL. (860) 349-1676